

LED Status Indicator

LED Blink Codes:

At power up, # of green blinks indicates configured throttle type:

- 1 Green = 0-5k
- 4 Green = EZ-GO inductive (ITS)
- 7 Green = CLUBCAR 5K-3-wire

Normal display status:

Solid Green: Controller ready to run

Solid Red: Controller in programming mode

Solid Yellow: Controller throttle is wide open, controller is supplying max output, and is not in current limit.

Trouble Shooting

Error code display:# of RED blinks indicates any error conditions that might exist:

- 1 Red = Throttle Position Sensor Over Range. Check for open wires.
- 2 Red = Under Temperature. Controller below -25C
- 3 Red = HPD. Throttle hasn't gone to zero during this power on cycle.
- 4 Red = Over Temperature. Controller over 95C
- 5 Red = Open Field
- 6 Red = Battery Under Voltage detected. Battery V < under voltage slider
- 7 Red = Battery Over Voltage detected. Battery V > overvoltage slider



LIMITED WARRANTY

Alltrax, Inc., (hereafter Alltrax) warrants that the product purchased is free from defects in materials or workmanship for a period of **2 years** from the date of manufacture. This warranty does not apply to defects due directly or indirectly to misuse, abuse, negligence, accidents, repairs, improper installation, submersion, alterations or use contrary to any instructions provided by Alltrax in verbal or written form.

In the event you should need warranty repair, contact Alltrax at (541) 476-3565 to receive warranty service authorization instructions for returning the defective product to Alltrax for evaluation. Products or parts shipped by customer to Alltrax must be sent postage paid and packaged appropriately for safe shipment. Alltrax is not responsible for customer products received without warranty service authorization and may be rejected.

Alltrax reserves the right to repair or replace merchandise at its option at no cost to the customer, except for shipping costs of sending the defect item to Alltrax. Replacement shall mean furnishing the customer with a new equivalent product to the defective item. Alltrax also reserves the right to make changes to any of its products or specifications without notice.

Alltrax assumes no liability for applications assistance or customer product design. Customers shall be responsible for evaluating the appropriateness of the use of any Alltrax product in any application. Customers shall provide adequate design and operating safeguards that are in compliance with standard practices of other similar applications or any standards of any governing agency.

THIS IS ALLTRAX INC.'S, SOLE WARRANTY.

NO REPRESENTATIVE EMPLOYEE, DISTRIBUTOR OR DEALER OF ALLTRAX HAS THE AUTHORITY TO MAKE OR IMPLY ANY WARRANTY, REPRESENTATION, PROMISE OR AGREEMENT, WHICH IN ANY WAY VARIES THE TERMS OF THIS LIMITED WARRANTY.

ALLTRAX PRODUCTS SOLD TO CUSTOMER ARE INTENDED TO BE USED ONLY IN THE APPLICATION SPECIFIED BY THE CUSTOMER TO ALLTRAX. ANY OTHER USE RENDERS THE LIMITED WARRANTY EXPRESSED HEREIN AND ALL IMPLIED WARRANTIES NULL AND VOID AND SAME ARE HEREBY EXCLUDED.

DISCLAIMER OF IMPLIED WARRANTIES

ALLTRAX, INC., SHALL IN NO EVENT BE LIABLE FOR DEATH, INJURIES TO PERSONS OR PROPERTY, OR FOR INCIDENTAL, CONTINGENT, OR CONSEQUENTIAL DAMAGES ARISING FROM THE USE OR MISUSE OF OUR PRODUCTS.

EXCEPT SPECIFICALLY PROVIDED HEREIN, THERE ARE NO OTHER WARRANTIES, EXPRESS OR IMPLIED, INCLUDING, BUT NOT LIMITED TO, ANY IMPLIED WARRANTIES OF MERCHANTABILITY OR FITNESS FOR A PARTICULAR PURPOSE. HOWEVER, SOME STATES DO NOT ALLOW LIMITATIONS ON HOW LONG AN IMPLIED WARRANTY LASTS, SO THE PRECEDING EXCLUSION

Alltrax, Inc.

1111 Cheney Creek Rd
Grants Pass, OR. 97527
Phone: 541-476-3565
Fax: 541-476-3566

Doc100-006-B_OP-DCX-Mini-Man.pub, 12-1-2010

ALLTRAX

www.alltraxinc.com

An Engineered Solution

DCX Mini-Manual For Golf Car Applications



- **Programmable**
- **300, 400, & 600 Amp**
- **24 to 48 Volt DC**
- **Regenerative Braking**
- **For Shunt Wound Motor**

www.alltraxinc.com

QUICK INSTALLATION GUIDE

DCX Wiring Diagram

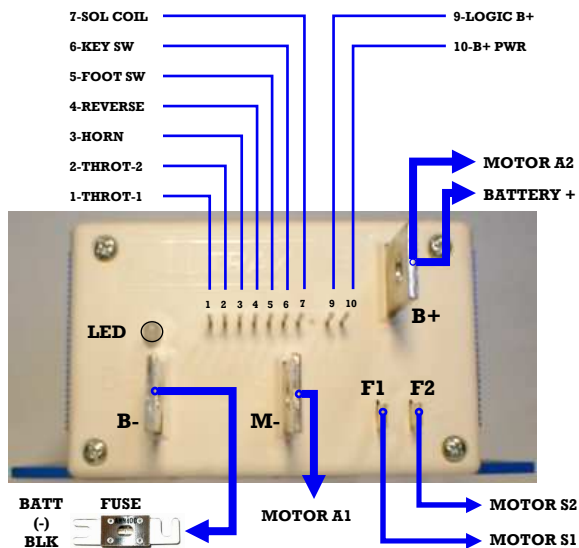

YAMAHA - G19



CLUB CAR - PD PLUS



CLUB CAR - IQ

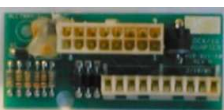

PDS

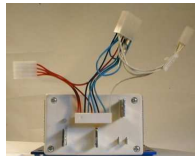

For complete instructions and wiring diagrams for other configurations and vehicles please download our DCX Operators Manual from www.alltraxinc.com

ControllerPRO

ControllerPRO is free user friendly software for customizing your Alltrax DCX Controllers. Download your copy of ControllerPRO from www.alltraxinc.com

Configuration

WARNING: Disconnect all battery charging sources while programming your DCX controller. The controllers RS-232 serial port is referenced to the B- battery connection.

Beware of any possible ground loop faults between your computer and the controller which could damage both the DCX Controller and PC, or cause personal injury.

Hardware: Use a STRAIGHT-THROUGH DB-9 pin / RS-232 serial interface cable to connect the controller to the PC. Alternatively use the preferred DB-9 pin RS-232 serial port to USB adapter.

The DCX controller must be powered before the ControllerPRO program will have any effect. Before programming the DCX, **READ THE SAFETY NOTES BELOW.** For bench programming prior to installation, a fused 18V or higher battery may be used to power the controller. Connect battery negative to the B- bus bar, battery positive to pin 5+6, 9+10 (Pin 8 is blank).

If you see an error "**Motor Controller is Not Responding**", verify the controller is powered up and the connections are inserted correctly. If the error message continues, uninstall then reinstall the drivers for the communications cable. If the problem persists, contact Alltrax Technical Support.



Safety Notes:

Alltrax recommends that all motor controller applications have a fuse in the battery circuit. Many vehicles do not have a fuse, and will need to have one installed. The following fuses manufactured by Bussman or Littelfuse are acceptable: For controllers rated at 400 amps or less use ANN250. On controllers rated at 450 amps or more use ANN400. [See Doc100-016-A_OP-Fuse-Install-Guide.doc]

Alltrax also recommends a diode across the coil of the solenoid if it is not already installed. A minimum of a 100V 1A diode (a 1N4004 is suitable) is required. See complete wiring diagrams for orientation.

Working on electric vehicles, sudden unexpected events can occur, it's recommended to:

- Place the drive axle on jack stands—wheels off the floor
- When working on wiring or batteries, always remove rings and watches and use the proper safety equipment, eye protection, and insulated tools
- Never connect a computer while the vehicle is being charged
- Disconnect batteries before installing or working on the controller

Alltrax, Inc.

1111 Cheney Creek Rd
Grants Pass, OR. 97527
Phone: 541-476-3565
Fax: 541-476-3566