

www.Alltraxinc.com

ALLTRAX

PERFORMANCE MOTOR CONTROLLERS

Operators Manual

AC1 Controller

DC Conversion

TXT48, PDS, DCS



Alltrax Inc

1111 Cheney Creek Road, Grants Pass, OR 97527 Ph: 541-476-3565 Fax: 541-476-3566

Web Site: <http://www.alltraxinc.com>

©ALLTRAX INC 2023 - All Rights Reserved

Contact Alltrax:

Phone: 541-476-3565 EXT 3
Fax: 541-476-3566

Email:

Tech Support: helpdesk@alltraxinc.com
Orders: orders@alltraxinc.com
Shipping: shipping@alltraxinc.com
General Inquires: info@alltraxinc.com

Website:

<http://www.alltraxinc.com>

Facebook:

<http://www.facebook.com/AlltraxInc>

Twitter:

<http://www.twitter.com/Alltraxinc>

**EZ-TXT / TXT48 Conversion Install Manual
DOC113-033 can be found on our website.**

TABLE OF CONTENTS

WARNINGS	5
AC TECHNICAL SPECIFICATIONS	6
TERMS AND DEFINITIONS	7
REQUIRED COMPONENT INFO	9
<i>SOLENOID/CONTACTORS</i>	10
<i>MAIN FUSE</i>	11
<i>WIRING</i>	12
<i>HIGH CURRENT</i>	13
<i>TEMP SENSOR</i>	14
<i>SPEED SENSOR</i>	15
E-Z-GO DCS	17
HARNESS PINOUTS	18
<i>SPEED AND TEMP SENSOR</i>	18
<i>PINOUT TABLE</i>	19
<i>16 PIN MOLEX TXT48</i>	20
<i>PINOUT TABLE 1/2</i>	21
<i>E-Z-GO PDS</i>	22
<i>PINOUT TABLE 1/2</i>	23
CONTROLLER DIMENSIONS	24
<i>TOP DOWN VIEW</i>	24
<i>SIDE VIEW</i>	25
<i>FRONT VIEW</i>	25
LED BLINK CODES	29
<i>THROTTLE AND BRAKE CODES</i>	29
<i>ALARM CODES</i>	30
<i>CODE DEFINITIONS</i>	32
WARRANTY STATEMENT	33

WARNINGS



GENERAL WARNINGS

Safety Notes:

When working on electric vehicles, sudden unexpected events can occur, it's recommended to:

- Place the drive axle on jack stands—wheels off the floor.
- When working on wiring or batteries, always remove rings, watches and secure dangling clothing/hair/jewelry.
- Use the proper safety equipment, eye protection, and insulated tools.
- Never connect a computer while the vehicle is being charged.
- Disconnect batteries before installing or working on the Alltrax controller.
- Wear safety glasses.
- Because hydrogen can build up due to gassing from the batteries, work in a well ventilated area.
- Make sure the battery pack is fused.
- Do not clean the controller with a high PSI pressure washer.
- When cleaning batteries, take precautions to keep the battery acid from splashing on the controller.

CAUTION:

It is the installer's responsibility to ensure the correct equipment (i.e. wire, motor, solenoid, fuse etc) is installed in the vehicle. Equipment should be sized correctly for planned usage. Failure to do so could pose a significant risk of explosion, fire, property damage and serious injury or death.

READ AND SAVE THESE INSTRUCTIONS

WARNINGS



USABILITY STATEMENT

Alltrax Inc's lines of AC Induction, IPM and SMPM Motor Controllers are intended for use with brushless motors only. Any application or usage that does not meet these criteria WILL NOT be covered by warranty. Also, any requests for design assistance or technical support outside the scope of the product intended use may be denied. Alltrax assumes no liability for any damage or injury as a result of use of the motor controllers in a non-traction or process motor application. See the warranty at the end of this manual.

WARNING: Use of this product for other than these specified uses may be highly dangerous and lead to serious injuries or death.

AC1 SPECIFICATIONS



Model	2 Min (Amps)	5 Min (Amps)	Continuous (Amps)
AC1-48650	650	500	400

Type: 3 phase AC

Operating Frequency:

Controller Voltage, KSI & Reverse: 48v controllers = 16v - 60v
72v controllers = 16v - 92v

Operating Temperature: -20c to 90c

Environmental Operating Temperature: -20c to 50c // 0F to 122F

Standby Current (Power up): 5mA

KSI & Rev Pin Input Current: 200mA max

Relay Drive Current: 4A max

Throttles Supported: 0-5k, 5k-0, E-Z-GO ITS,
5k-0 3 Wire, 0-5v, USB
Throttle, Absolute Mode

Terminal Bolt Torque: 60-80 in.lb (5-7ft.lb, 6.77-9.4nm)

Mounting Bolt Torque: 15-20 in.lb (1.25-1.75 ft.lb,
1.7-2.25nm)

Terms and Definitions

IPM: *Internal Permanent Magnet*

SMPM: *Surface Mount Permanent Magnet*

KI: *Integral Gain for PI/PID controllers*

KP: *Proportional Gain for PI/PID controllers*

KD: *Derivative Gain for PI/PID controllers*

Quadrature: *Most common type of Speed Sensor Signal used in AC Induction motor applications*

Sine/Cosine: *Commonly used for speed sensors in IPM and SMPM motor applications.*

ITS: *Inductive Throttle System, used in DC EZGOs*

KSI: *Key switch input, refers to signal voltage from the KEY*

Roll Detect: *Is a feature that uses the speed sensor to determine whether or not the cart is moving with no active throttle.*

Unique Features

Low Voltage Protection -

If battery voltage falls below your set Under Voltage limit the controller will shut off the power supply completely to prevent the batteries from getting drained to the point of damaging themselves. If you plug the controller into the toolkit software you will get a large SHUTDOWN warning to notify you of what happened. You can bring power back by cycling the TOW/RUN or plugging your charger back into the cart.

Trigger Limits -

1v for one hour

5v under shutdown triggered in 5 minutes

10v under shutdown triggered in 1 minute

COMPONENTS

Heavy Duty Contactors



Main Fuse



Heavy Gauge Wires



Contactors (Solenoids)



The solenoid is the primary disconnect of the battery pack in the case of the an emergency. In order to be effective, the solenoid needs to be properly rated for the current that will be drawn from the batteries. It is VERY important that the solenoid be rated correctly. It is the only way to disconnect the batteries from the motor/controller loop in case of a failure. Too small of a solenoid increases the likelihood that the contacts will weld together and not be able open.

When installing a new controller, Alltrax recommends the OEM solenoids be replaced with a heavy duty version. See below for suggested sizing of solenoid replacements.

As a regular part of a preventative maintenance plan, solenoids should be replaced every 3-5 years.



Heavy Duty 400A

(800-1000A inrush)

A heavy duty solenoid is required when using any of the AC1 controllers. You need a minimum of 400A continuous and 800A inrush rating.

Recommended Models

MZJ400 (Shown)

SW200 (Albright)

SOL600

Fuse

Any application where there is a battery pack, a fuse must be installed. A fuse will open the battery circuit and prevent any serious damage from occurring.

The fuse should be installed on or between the battery terminals. The main battery positive OR main battery negative OR in-between 2 batteries is an acceptable location for fuse installation. The fuse must be rated for pack voltage and fault current.



Controller Amperage	Fuse Style / Rating
650A	ANN / 400A
750A	

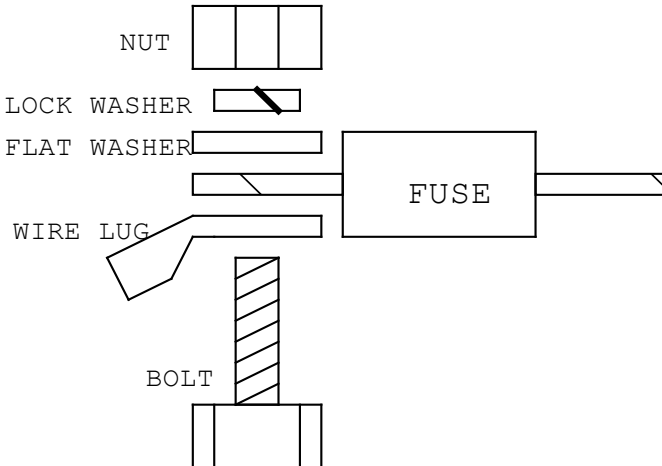

Diagram: Fuse terminal hardware

Wiring

Wiring and battery health in an electric vehicle are very important and overlooked during performance upgrades. Wiring size is important for safety and proper operation of the vehicle. Undersized wires will affect the performance of controllers and can overheat. Wires should be crimped with proper sized terminals and tools to provide a clean low resistance connection.

Controller	Min. Wire AWG Standard Duty	Min. Wire AWG Heavy Duty
650A	2 AWG	1/0 AWG

Power Wiring

When running wiring for the vehicle care must be taken for proper wire routing. Power wiring should be of proper sizing and ran as low in the framework of the vehicle as practical. Lengths of power wire runs need to be kept short and pairs of wires from common circuits should be grouped together to reduce EMC emissions. Secure all power wiring to the vehicle framework.

Motor Phase Wiring

The three phase wires should be kept close to the same length and kept together as they run from the motor to the controller. For optimum reliability don't lay wire across other connections on the controller. Low current wires should not be run alongside the motor wiring or any high current wiring.

****Never swap motor phase wiring unless key is off and vehicle is not moving****

High Current Connections

TERMINAL	FUNCTION
B+	Battery positive to Controller
B-	Battery negative to Controller
R	Brake Resistor
U	Motor phase U
V	Motor phase V
W	Motor phase W

LUG ASSEMBLY

The AC controller comes with 5-6 stainless steel 1/4-20 bolts for holding the high current terminals to the controller.

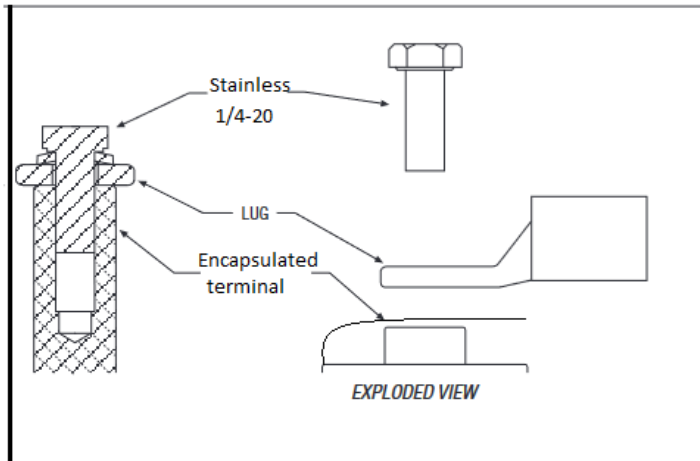

Low Power Wiring

Signal Wiring

Signal wires should be kept as short as practical. Care should be taken to protect the wires from sharp edges and rubbing. Consider the use of split loom or braided wire sheathing. Fasten bundles securely to framework. Do not route the signal wires together in the same bundle with power wires.

Temp Sensor

Induction motors come with a two wire temp sensor which the controller uses to monitor internal temps during operation. On DC conversions the temp sensor will run through the same harness connector as your speed sensor.

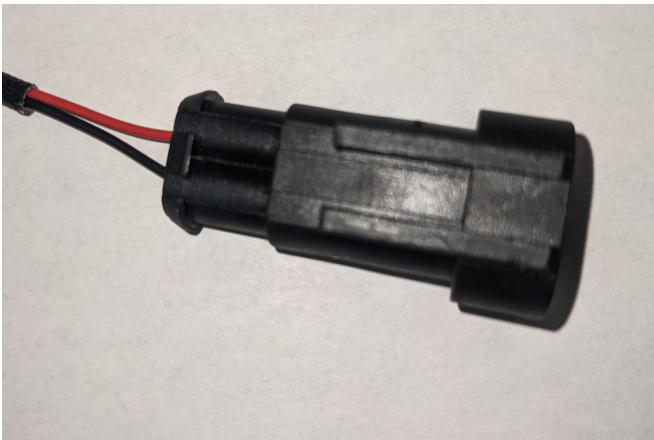

Speed Sensor Information

The speed sensor is a small group of wires attached to the side of the motor. Induction motors use a Quadrature signal that gives up to 64 readings per minute. Speed sensors are currently required.

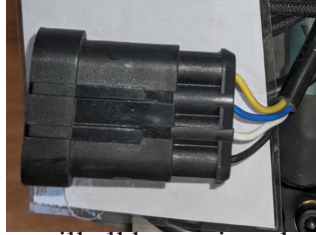

Carts that came stock with an AC motor will all be equipped to use the Quadrature sensor. For AC Conversion applications a harness adapter will be used to get the correct signal to the controller without replacing the existing harness.



In the future a sensorless option will be available but currently speed sensors are required for all ACT induction applications.

Speed and Temp sensor cable



All DC conversion systems will come with a new speed and temp sensor cable to match the new AC motor. We recommend not running this harness parallel to your high current wires. An example would be zip tying them to your large gauge motor wires. Even with shielded wires this can potentially cause issues with the signal. Each connector can only be plugged into one location on the cart/controller but there is a full break down of each connector on the following page. TXT version is 48” long.

Encoder Pulses/Revolution Constraint (Quadrature Encoder)

The maximum encoder frequency the controller will accept is 10 kHz. To determine how fast this constraint will allow the motor to spin, use the equation:

$$\text{Max Speed Encoder Limit} = 600000 / \text{Encoder Size}$$
(e.g., a motor with 128-pulse encoder can run up to 4587 rpm).

Firmware Max Speed Constraint

The maximum motor speed the controller will allow is 10,000 rpm.

$$\text{Max Sped RPM Limit} = 10,000$$

E-Z-GO DCS INFORMATION

ATTENTION E-Z-GO DCS OWNERS

To run the AC1 conversion kit you will need to replace your factory wiring harness with an E-Z-GO TXT48 harness. The DCS harness only has 9 wires and would limit functionality of the AC1 controller.



Wire Harness Pinouts

Speed and Temp sensor harness connectors Used on all DC conversions

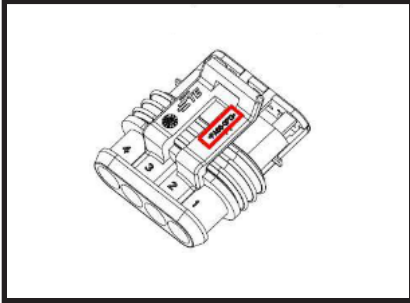

C3 - TE Superseal 4P connector used for the speed sensor signal of the motor. Water resistant connector.

C2 - TE Superseal 2P connector used for the motor temp sensor harness. Water resistant connector.

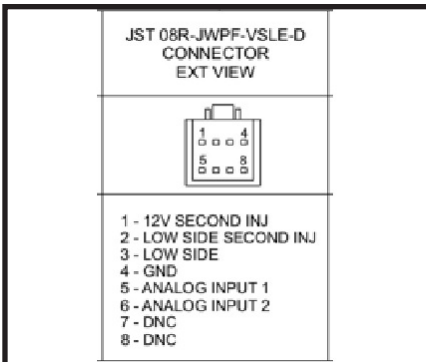
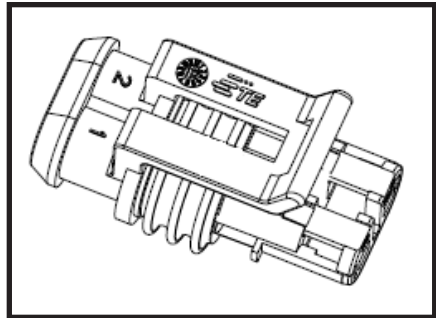

C1 - JST-JWPF O8 connector used for the controller side connection of the Speed and Temp sensor harness. Water resistant connector.

C1, C2, C3 pinouts for Alltrax harness

PIN	NAME	DESCRIPTION
**	C1	CONNECTOR
1		
2		
3		
4		
5		
6	Not Used	Not Used
7	Temp Sensor Lo	
8	Temp Sensor Hi	
**	C2	CONNECTOR
1	Temp Sensor Lo	
2	Temp Sensor Hi	
**	C3	CONNECTOR
1		
2		
3		
4		

WIRE HARNESS PINOUT

16 pin MOLEX connector E-Z-GO TXT48

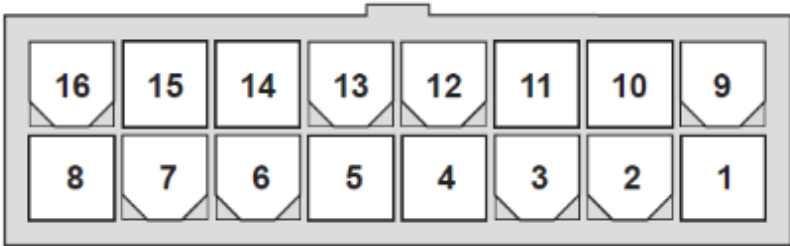

Female side, top down view of controllers connector.

For DC conversions this connector is used on the stock E-Z-GO TXT48 which came as a 48v. The cart side uses the 16 pin MOLEX 'Mini-fit jr' male housing (see below image) and the 18-24awg crimps.

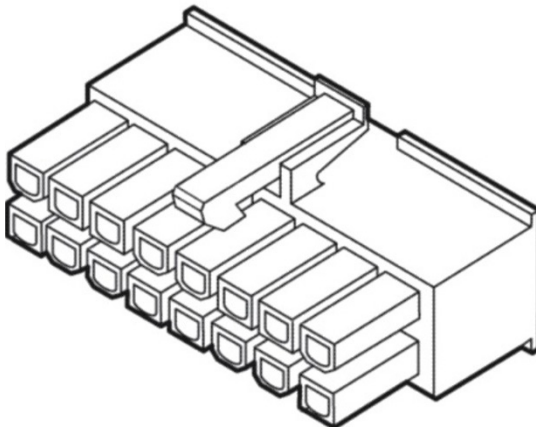

16 PIN TABLE

PIN	NAME	DESCRIPTION
1	Throttle High	Hi side of throttle, white wire
2	Throttle Wiper	Lo side throttle signal, black wire
3	Throttle Low	Unused on E-Z-GO applications
4	User 1	Signal voltage for User 1 control
5	Charger Disable	Charge interlock/disable
6	Foot Switch	Throttle activated microswitch
7	Horn Neg	Floating ground for horn
8	Forward	Forward direction signal
9	Run/Tow	Main low power voltage reference
10	Key Switch	Secondary low power voltage reference
11	User 2	Signal voltage for User 2 control
12	Solenoid Negative	Floating ground for solenoid activation
13	Tach Negative	Unused in DC to AC conversions
14	Tach Out	Unused in DC to AC conversions
15	Tach Reference	Unused in DC to AC conversions
16	Reverse	Reverse direction signal

WIRE HARNESS PINOUT

PDS MOLEX connectors

Flat 4 pin

Square 4 pin

Rectangle 10 pin

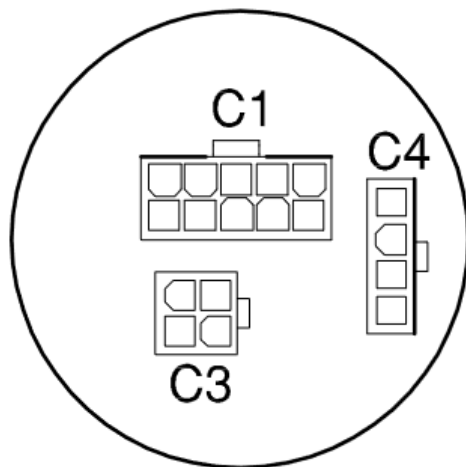

The E-Z-GO PDS connects with 4 harnesses. The three used with the AC1 conversion are showed in the picture above. The missing connector is used for the speed sensor on the stock vehicle. With the Alltrax AC1 conversion you will be using a new speed sensor and temp sensor wire coming directly off the motor (in most cases).

PDS PINOUT TABLE

PIN	NAME	DESCRIPTION
**	C1	CONNECTOR
1	FnR Feed	Output from controller to FnR switch
2	Reverse	Reverse input from FnR switch
3	Forward	Forward input from the FnR switch
4	Reedswitch Logic	The reedswitch supplies logic power when the charger is disconnected.
5	Logic	Battery reference voltage
6	Solenoid Neg	Lo side logic for controlling solenoid
7	Solenoid Pos	Hi side logic for controlling solenoid
8	KSI logic	Logic signal from key to controller
9	KSI	Signal feed from controller to key
10	Horn	Control signal for reverse buzzer
**	C3	CONNECTOR
1	Logic Input	Reference voltage from controller
2	KSI Logic	Logic input for keyswitch
3	Logic Input	Reference voltage from controller
4	Tow/Run	Tow/Run reference
**	C4	CONNECTOR
1	FS OUT	Footswitch signal output
2	FS IN	Footswitch signal input
3	ITS throttle	Throttle reference
4	ITS throttle	Throttle signal

CONTROLLER DIMENSIONS

TOP DOWN VIEW

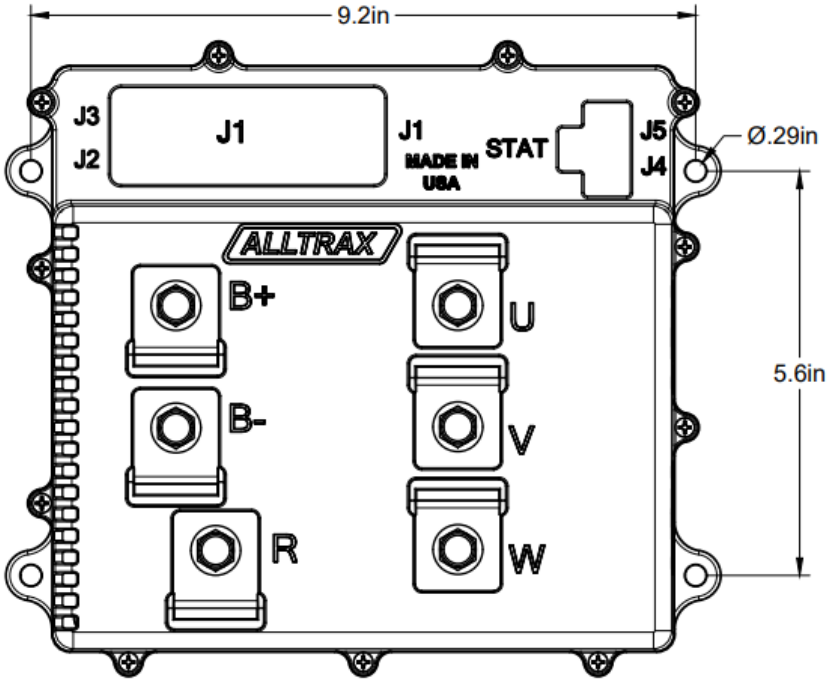

CONTROLLER DIMENSIONS

SIDE VIEW

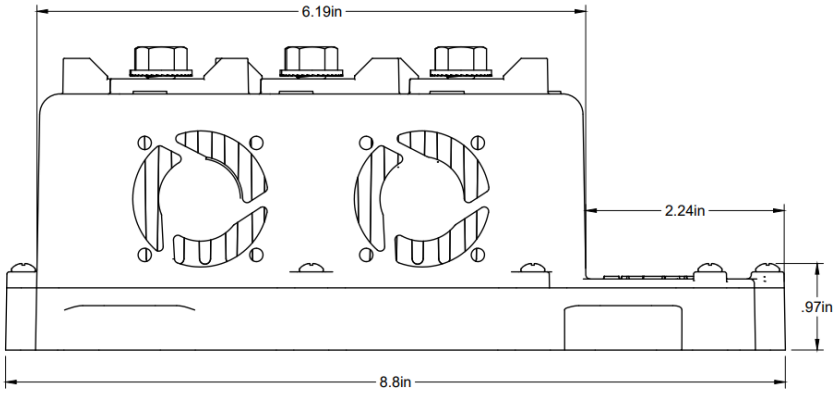

FRONT VIEW

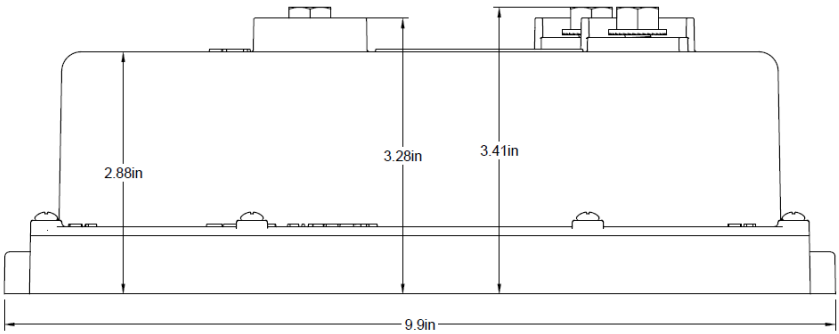

E-Z-GO TXT48 CONVERSION

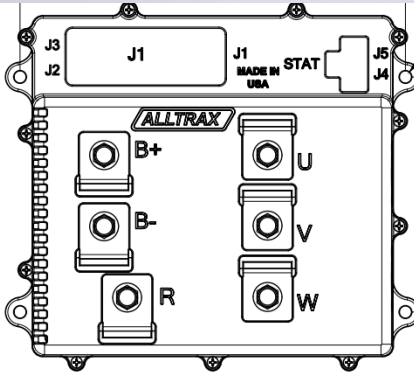

16	15	14	13	12	11	10	9
8	7	6	5	4	3	2	1

J1 - For an indepth pinout of the harness see pages 20-21 of this manual

- J1** - Main wire harness connector
- J2** - Personality Switch
- J3** - AC Motor case ground
- J4** - Can Bus
- J5** - Programming port (USB A)

- B+** Positive from Solenoid
- B-** Battery Negative
- R** Not used for conversions
- U** U of the Motor
- V** V of the Motor
- W** W of the Motor

E-Z-GO PDS CONVERSION

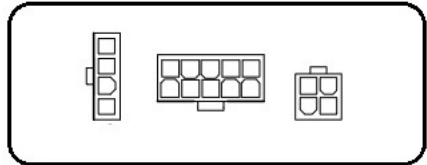
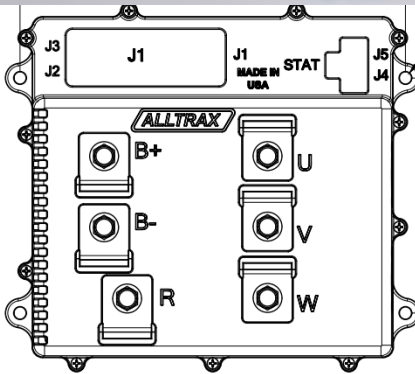

J1 - For an indepth pinout of each connector see pages 22-23. Factory 3 pin speed sensor harness not used in AC conversions.

- J1** - Main wire harness connector
- J2** - Personality Switch
- J3** - AC Motor case ground
- J4** - Can Bus
- J5** - Programming port (USB A)

- B+** Positive from Solenoid
- B-** Battery Negative
- R** Large resistor connection
- U** U of the Motor
- V** V of the Motor
- W** W of the Motor

PROGRAMMING THE CONTROLLER

Controllers ordered for stock configuration come pre-programmed and do not need to be programmed before use. If the user would like to customize their performance or has upgraded their motor and needs a matching motor map the controller can be connected to a computer with a USB A to B, commonly referred to as a “printer cable”.



The USB A to B cable is used to connect your motor controller to your personal computer. Using the free Alltrax Toolkit you can customize your performance to match your needs.

The Alltrax Toolkit software can be
downloaded from:
<https://alltraxinc.com/ac-toolkit-software/>
No purchase necessary

[DOWNLOAD SOFTWARE](#)

AC Toolkit Software Manual

[AC Toolkit Software Manual](#)

BLINK CODES

On power up, the controller will blink out a throttle code and then a Status or Error Code (see below)

Throttle Type Codes:

1 Green LED Flash	=	2-wire 0-5k throttle
2 Green LED Flash	=	2-wire 5K-0 throttle
3 Green LED Flash	=	0-5V throttle
4 Green LED Flash	=	EZGO ITS throttle
5 Green LED Flash	=	3-wire 0-5k
6 Green LED Flash	=	6 to 10.5 Taylor Dunn throttle
7 Green LED Flash	=	MCOR
8 Green LED Flash	=	Reserved
9 Green LED Flash	=	Pump
10 Green LED Flash	=	USB Throttle
11 Green LED Flash	=	Absolute Throttle
12 Green LED Flash	=	PWM_Throttle

Brake Type Codes:

1 Green LED Flash	=	2-wire 0-5k throttle
2 Green LED Flash	=	2-wire 5K-0 throttle
3 Green LED Flash	=	0-5V throttle
4 Green LED Flash	=	Reserved
5 Green LED Flash	=	3-wire 0-5k
6 Green LED Flash	=	6 to 10.5 Taylor Dunn throttle
7 Green LED Flash	=	MCOR
8 Green LED Flash	=	Reserved
9 Green LED Flash	=	Reserved
10 Green LED Flash	=	USB Throttle
11 Green LED Flash	=	Absolute Throttle

BLINK CODES

Normal Display Status:

Solid Green Light	=	Controller Ready to Run
Solid Red Light	=	Controller in programming mode
Solid Yellow Light	=	Throttle is wide open and the controller is <u>NOT</u> in Current Limit
Blinking Yellow Light	=	Throttle is wide open, but the controller is in Current Limit

Error Codes:

AC alarm codes flash a sequence of green then red. All alarms are self clearing and will repeat until the error condition has been corrected.

1 Green and 1 Red LED Flash	=	Short Circuit/Output Fault
1 Green and 2 Red LED Flash	=	Battery Under Voltage
1 Green and 3 Red LED Flash	=	Battery Over Voltage
1 Green and 4 Red LED Flash	=	Over temperature
1 Green and 5 Red LED Flash	=	Throttle Power Fault
1 Green and 6 Red LED Flash	=	Pre-Charge Failure
2 Green and 1 Red LED Flash	=	Throttle/Brake Range
2 Green and 2 Red LED Flash	=	Bad Variables
2 Green and 3 Red LED Flash	=	High Throttle Over range
2 Green and 4 Red LED Flash	=	High Throttle Under range
2 Green and 5 Red LED Flash	=	Low Throttle Over range
2 Green and 6 Red LED Flash	=	Low Throttle Under range
3 Green and 1 Red LED Flash	=	Throttle/Brake Range
3 Green and 2 Red LED Flash	=	Bad Variable Set Loaded
3 Green and 3 Red LED Flash	=	Relay Coil Overcurrent
3 Green and 4 Red LED Flash	=	Brake Coil Overcurrent
3 Green and 5 Red LED Flash	=	Reserved Overcurrent*
3 Green and 6 Red LED Flash	=	Horn Overcurrent
4 Green and 1 Red LED Flash	=	Reserved
4 Green and 2 Red LED Flash	=	Reserved
4 Green and 3 Red LED Flash	=	Hardware Failure
4 Green and 4 Red LED Flash	=	Startup Failure
4 Green and 5 Red LED Flash	=	Reserved
4 Green and 6 Red LED Flash	=	Reserved
5 Green and 1 Red LED Flash	=	General Error

CODE DEFINITIONS

Error Code Definitions:

- Short Circuit/Output Fault:
Controller detected a short circuit or other fault on the output circuit.
Check wiring.
- Battery Under Voltage:
B+ Voltage lower than Low Voltage Battery Setting. Check pack voltage or program settings.
- Battery Over Voltage:
B+ Voltage Higher than Over Voltage Battery Setting. Check pack voltage or program settings
- Over temperature:
Busbar temperature exceeds 90°C. Let controller cool and/or add fan.
- Throttle power Fault:
This is a 5V fault, if the speed sensor gets damaged this alarm will be one of the alarms triggered. Can also be caused by a fault in voltage based throttles
- Pre-charge Failure:
B+ voltage and KSI voltage differ by more than 5v. Stuck solenoid.
- Under Temp:
Busbar Temperature reads less than -20°C
- High Throttle Over range & High Throttle Under range:
High Side of throttle signal is outside of acceptable window for that throttle type. Check and/or replace throttle. Change throttle type to correct throttle installed on car.
- Low Throttle Over range & Low Throttle Under range:
Low Side of throttle signal is outside of acceptable window for that throttle type. Check and/or replace throttle. Change throttle type to correct throttle installed on car.
- Bad Variable Set Loaded:
Alltrax loaded variable data is missing or corrupted. Contact Alltrax
- Throttle/Brake Range:
The RXV has a “throttle” built into the brake pedal to communicate with the motor brake. This alarm indicates an error in that signal.

CODE DEFINITIONS

Error Code Definitions:

- **Relay coil overcurrent:**
Relay coil has shorted, the wires were attached incorrectly or the suppression control diode is backwards.
- **Brake coil overcurrent:**
Short in the brake pedals resistor coil. Presently this can only trigger on EZGO RXV applications
- **Horn Overcurrent:**
There is a short in the horn circuit, could be wiring or horn related

WARRANTY STATEMENT

Alltrax, Inc., (hereafter Alltrax) warrants that the product purchased is free from defects in materials or workmanship for a period of 2 years from the date of manufacture. This warranty does not apply to defects due directly or indirectly to misuse, abuse, negligence, accidents, repairs, improper installation, submersion, alterations or use contrary to any instructions provided by Alltrax in verbal or written form.

In the event you should need warranty repair, contact Alltrax at (541) 476-3565 to receive warranty service authorization instructions for returning the defective product to Alltrax for evaluation. Products or parts shipped by customer to Alltrax must be sent postage paid and packaged appropriately for safe shipment. Alltrax is not responsible for customer products received without warranty service authorization and may be rejected.

Alltrax reserves the right to repair or replace merchandise at its option at no cost to the customer, except for shipping costs of sending the defect item to Alltrax. Replacement shall mean furnishing the customer with a new equivalent product to the defective item. Alltrax also reserves the right to make changes to any of its products or specifications without notice.

Alltrax assumes no liability for applications assistance or customer product design. Customers shall be responsible for evaluating the appropriateness of the use of any Alltrax product in any application. Customers shall provide adequate design and operating safeguards that are in compliance with standard practices of other similar applications or any standards of any governing agency.

THIS IS ALLTRAX INC.'S, SOLE WARRANTY.

NO REPRESENTATIVE EMPLOYEE, DISTRIBUTOR OR DEALER OF ALLTRAX HAS THE AUTHORITY TO MAKE OR IMPLY ANY WARRANTY, REPRESENTATION, PROMISE OR AGREEMENT, WHICH IN ANY WAY VARIES THE TERMS OF THIS LIMITED WARRANTY.

ALLTRAX PRODUCTS SOLD TO CUSTOMER ARE INTENDED TO BE USED ONLY IN THE APPLICATION SPECIFIED BY THE CUSTOMER TO ALLTRAX. ANY OTHER USE RENDERS THE LIMITED WARRANTY EXPRESSED HEREIN AND ALL IMPLIED WARRANTIES NULL AND VOID AND SAME ARE HEREBY EXCLUDED.

DISCLAIMER OF IMPLIED WARRANTIES

ALLTRAX, INC., SHALL IN NO EVENT BE LIABLE FOR DEATH, INJURIES TO PERSONS OR PROPERTY, OR FOR INCIDENTAL, CONTINGENT, OR CONSEQUENTIAL DAMAGES ARISING FROM THE USE OR MISUSE OF OUR PRODUCTS.

EXCEPT SPECIFICALLY PROVIDED HEREIN, THERE ARE NO OTHER WARRANTIES, EXPRESS OR IMPLIED, INCLUDING, BUT NOT LIMITED TO, ANY IMPLIED WARRANTIES OF MERCHANTABILITY OR FITNESS FOR A PARTICULAR PURPOSE. HOWEVER, SOME STATES DO NOT ALLOW LIMITATIONS ON HOW LONG AN IMPLIED WARRANTY LASTS, SO THE PRECEDING EXCLUSION MAY NOT APPLY TO YOU.

“Thank you Nikola Tesla, for a better motor”