



Contact Alltrax:

Phone: 541-476-3565 EXT 3

Email:

Tech Support: [helpdesk@alltraxinc.com](mailto:helpdesk@alltraxinc.com)

Orders: [orders@alltraxinc.com](mailto:orders@alltraxinc.com)

General Inquires: [info@alltraxinc.com](mailto:info@alltraxinc.com)

Website:

<http://www.alltraxinc.com>

Facebook:

<http://www.facebook.com/AlltraxInc>

Twitter:

<http://www.twitter.com/Alltraxinc>

**Bluetooth® is a registered trademark of Bluetooth SIG, Inc**

# TABLE OF CONTENTS

---

<b>WARNINGS</b>	<b>5</b>
<b>AC TECHNICAL SPECIFICATIONS</b>	<b>8</b>
<b>TERMS AND DEFINITIONS</b>	<b>9</b>
<b>REQUIRED COMPONENT INFO</b>	<b>11</b>
<i>SOLENOID/CONTACTORS</i>	<b>12</b>
<i>MAIN FUSE</i>	<b>13</b>
<i>WIRING</i>	<b>14</b>
<i>HIGH CURRENT</i>	<b>15</b>
<i>TEMP SENSOR</i>	<b>16</b>
<i>SPEED SENSOR</i>	<b>17</b>
<b>MOUNTING PANEL</b>	<b>19</b>
<b>HARNESS PINOUTS</b>	<b>20</b>
<i>SPEED AND TEMP SENSOR</i>	<b>20</b>
<i>PINOUT TABLE</i>	<b>21</b>
<i>26 PIN JAE/YDRE CONNECTOR</i>	<b>22</b>
<i>PINOUT TABLE 1/2</i>	<b>23</b>
<i>PINOUT TABLE 2/2</i>	<b>24</b>
<i>23 PIN AMP SEAL CONNECTOR</i>	<b>25</b>
<i>PINOUT TABLE 1/2</i>	<b>26</b>
<i>PINOUT TABLE 2/2</i>	<b>27</b>
<b>CONTROLLER DIMENSIONS</b>	<b>28</b>
<i>TOP DOWN VIEW</i>	<b>28</b>
<i>SIDE VIEW</i>	<b>29</b>
<i>FRONT VIEW</i>	<b>29</b>
<b>CONTROLLER SCHEMATICS</b>	<b>31</b>
<i>G29/YDRE</i>	<b>31</b>
<i>G19 &amp; G22</i>	<b>33</b>
<b>LED BLINK CODES</b>	<b>35</b>
<i>THROTTLE AND BRAKE CODES</i>	<b>35</b>
<i>ALARM CODES</i>	<b>36</b>
<i>CODE DEFINITIONS</i>	<b>37</b>
<b>WARRANTY STATEMENT</b>	<b>39</b>

# WARNINGS

---



## GENERAL WARNINGS

---

### Safety Notes:

When working on electric vehicles, sudden unexpected events can occur, it's recommended to:

- Place the drive axle on jack stands—wheels off the floor.
- When working on wiring or batteries, always remove rings, watches and secure dangling clothing/hair/jewelry.
- Use the proper safety equipment, eye protection, and insulated tools.
- Never connect a computer while the vehicle is being charged.
- Disconnect batteries before installing or working on the Alltrax controller.
- Wear safety glasses.
- Because hydrogen can build up due to gassing from the batteries, work in a well ventilated area.
- Make sure the battery pack is fused.
- Do not clean the controller with a high PSI pressure washer.
- When cleaning batteries, take precautions to keep the battery acid from splashing on the controller.

### CAUTION:

It is the installer's responsibility to ensure the correct equipment (i.e. wire, motor, solenoid, fuse etc) is installed in the vehicle. Equipment should be sized correctly for planned usage. Failure to do so could pose a significant risk of explosion, fire, property damage and serious injury or death.

## READ AND SAVE THESE INSTRUCTIONS

# WARNINGS

---



## **USABILITY STATEMENT**

---

Alltrax Inc's lines of AC Induction and PMAC Motor Controllers are intended for use with brushless motors only. Any application or usage that does not meet these criteria WILL NOT be covered by warranty. Also, any requests for design assistance or technical support outside the scope of the product intended use may be denied. Alltrax assumes no liability for any damage or injury as a result of use of the motor controllers in a non-traction or process motor application. See the warranty at the end of this manual.

**WARNING:** Use of this product for other than these specified uses may be highly dangerous and lead to serious injuries or death.



## **VOLTAGE SETTINGS**

The Alltrax AC1 controller works for a wide range of voltage applications. If you're running aftermarket lithium batteries, a higher voltage than standard or if this is a custom application we highly recommend you check your settings. For detailed instructions you can see our Toolkit operators manual. If the settings aren't correct it can limit torque, limit speed or even prevent operation.



## **THROTTLE SETTING**

It's important to make sure your throttle is correct for your application. The ITS throttle type should ONLY be used on DC EZGO applications being converted to the AC1 controller. All factory AC EZGO are 0-5v. Setting the controller for ITS when the car is equipped with a 0-5v throttle can potentially damage the factory throttle.

# WARNINGS

---



## OPERATOR SAFETY

---

### WARNING:

### **AFTERMARKET PERFORMANCE UPGRADE — INHERENT RISK / OPERATOR RESTRICTIONS**

This controller is an aftermarket upgrade for golf carts and can significantly increase speed and torque and change handling and stability. When combined with modifications such as lift kits and/or larger tires, the center of gravity may increase and rollover risk may be significantly higher. Improper installation, wiring, setup, programming, incompatible equipment, or unsafe operation can result in loss of control, rollover, serious injury or death, and vehicle/property damage.

Use of this equipment for drag racing, competition, or high-speed operation is strictly prohibited and immediately voids all warranties and technical support eligibility.

Only trained, responsible operators should drive. Do not permit operation by anyone who is impaired by alcohol, drugs, or medication. Where a driver's license is required for the location of operation (including public roads where permitted), the operator must hold a valid driver's license. Minors should operate only where legally permitted and only under direct adult supervision



# WARNINGS

---



## OPERATOR SAFETY

---

**SAFETY RECOMMENDATION:  
USE PROFILE LOCKOUT  
(available on the FN-KEY Box)  
WHEN OTHERS MAY DRIVE**

If your cart may be operated by other drivers (including minors, guests, employees, or less-experienced operators), we strongly recommend using the optional FN-KEY Box to create and lock a conservative/limited-performance drive profile. The FN-KEY Box's keyed switch allows you to select among user profiles and helps prevent changes to locked settings without the key. Keep the key under adult control. Important: Profile lockout can help reduce the risk of unsafe settings, but it does not eliminate the inherent risks of increased speed/torque, loss of control, rollover, serious injury or death, or damage.

Use only as instructed. Start with conservative settings and test in a controlled area before normal operation. Always follow applicable laws and safe driving practices.



# AC1 SPECIFICATIONS



Model	1 Min (Phase Amps)	Continuous (Phase Amps)
AC1-72650	650	250

Type: 3 phase AC

Operating Frequency:

Controller Voltage, KSI & Reverse: 48v controllers = 16v - 60v  
72v controllers = 16v - 90v

Operating Temperature: -20c to 90c

Environmental Operating Temperature: -20c to 50c // 0F to 122F

Standby Current (Power up): 5mA

KSI & Rev Pin Input Current: 200mA max

Relay Drive Current: 4A max

Throttles Supported: 0-5k, 5k-0, E-Z-GO ITS,  
5k-0 3 Wire, 0-5v, USB  
Throttle, Absolute Mode

Terminal Bolt Torque: 60-80 in.lb (5-7ft.lb, 6.77-9.4nm)

Mounting Bolt Torque: 15-20 in.lb (1.25-1.75 ft.lb,  
1.7-2.25nm)

## **Terms and Definitions**

**IPM:** *Internal Permanent Magnet*

**SMPM:** *Surface Mount Permanent Magnet*

**KI:** *Integral Gain for PI/PID controllers*

**KP:** *Proportional Gain for PI/PID controllers*

**KD:** *Derivative Gain for PI/PID controllers*

**Quadrature:** *Most common type of Speed Sensor Signal used in AC Induction motor applications*

**Sine/Cosine:** *Commonly used for speed sensors in IPM and SMPM motor applications.*

**ITS:** *Inductive Throttle System, used in DC EZGOs*

**KSI:** *Key switch input, refers to signal voltage from the KEY*

**Roll Detect:** *Is a feature that uses the speed sensor to determine whether or not the cart is moving with no active throttle.*

**G29:** *Another model name for the YDRE and YDRE 2 DC systems.*

## **Unique Features**

### **Low Voltage Protection -**

If battery voltage falls below your set Under Voltage limit the controller will shut off the power supply completely to prevent the batteries from getting drained to the point of damaging themselves. If you plug the controller into the toolkit software you will get a large SHUTDOWN warning to notify you of what happened. You can bring power back by cycling the TOW/RUN or plugging your charger back into the cart.

#### ***Trigger Limts -***

*1v for one hour*

*5v under shutdown triggered in 5 minutes*

*10v under shutdown triggered in 1 minute*

### **Encoder Pulses/Revolution Constraint (Quadrature Encoder)**

The maximum encoder frequency the controller will accept is 10 kHz. To determine how fast this constraint will allow the motor to spin, use the equation:

$$\text{Max Speed Encoder Limit} = 600000 / \text{Encoder Size}$$

*(e.g., a motor with 128-pulse encoder can run up to 4587 rpm).*

### **Firmware Max Speed Constraint**

The maximum motor speed the controller will allow is 10,000 rpm.

$$\text{Max Sped RPM Limit} = 10,000$$

### **Alltrax Bluetooth® Mini BLE**

The AC172650 controllers now feature Bluetooth® wireless technology and can communicate with your phone using our AC Toolkit App found on the iOS and Android app stores. For information on use, see document Doc113-054 which should be included in the box with your controller but can also be found on [www.alltraxinc.com](http://www.alltraxinc.com)

# COMPONENTS

---

Heavy Duty Contactors



Main Fuse



Heavy Gauge Wires



Alltrax Mini BLE



## ***Contactors (Solenoids)***

---



The solenoid is the primary disconnect of the battery pack in the case of the an emergency. In order to be effective, the solenoid needs to be properly rated for the current that will be drawn from the batteries. It is VERY important that the solenoid be rated correctly. It is the only way to disconnect the batteries from the motor/controller loop in case of a failure. Too small of a solenoid increases the likelihood that the contacts will weld together and not be able open.

When installing a new controller, Alltrax recommends the OEM solenoids be replaced with a heavy duty version. See below for suggested sizing of solenoid replacements.

As a regular part of a preventative maintenance plan, solenoids should be replaced every 3-5 years.



---

### **Heavy Duty 400A**

*(800-1000A inrush)*

A heavy duty solenoid is required when using any of the AC1 controllers. You need a minimum of 400A continuous and 800A inrush rating.

#### **Recommended Models**

MZJ400 (Shown)

SW200 (Albright)

SOL600

## Fuse

Any application where there is a battery pack, a fuse must be installed. A fuse will open the battery circuit and prevent any serious damage from occurring.

The fuse should be installed on or between the battery terminals. The main battery positive OR main battery negative OR in-between 2 batteries is an acceptable location for fuse installation. The fuse must be rated for pack voltage and fault current.



Controller Amperage	Fuse Style / Rating
650A	ANN / 400A

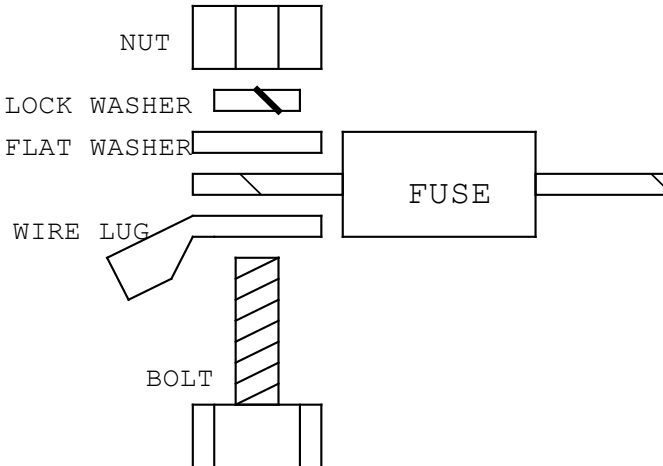

**Diagram: Fuse terminal hardware**

## Wiring

Wiring and battery health in an electric vehicle are very important and overlooked during performance upgrades. Wiring size is important for safety and proper operation of the vehicle. Undersized wires will affect the performance of controllers and can overheat. Wires should be crimped with proper sized terminals and tools to provide a clean low resistance connection.

Controller	Min. Wire AWG Standard Duty	Min. Wire AWG Heavy Duty
650A	2 AWG	1/0 AWG

### Power Wiring

When running wiring for the vehicle care must be taken for proper wire routing. Power wiring should be of proper sizing and ran as low in the framework of the vehicle as practical. Lengths of power wire runs need to be kept short and pairs of wires from common circuits should be grouped together to reduce EMC emissions. Secure all power wiring to the vehicle framework.

### Motor Phase Wiring

The three phase wires should be kept close to the same length and kept together as they run from the motor to the controller. For optimum reliability don't lay wire across other connections on the controller. Low current wires should not be run alongside the motor wiring or any high current wiring.

*\*\*\*Never swap motor phase wiring unless key is off and vehicle is not moving\*\*\**

# High Current Connections

TERMINAL	FUNCTION
B+	Battery positive to Controller
B-	Battery negative to Controller
R	Not Used
U	Motor phase U
V	Motor phase V
W	Motor phase W

## LUG ASSEMBLY

The AC controller comes with 5 stainless steel 5/16-16 bolts for holding the high current terminals to the controller.

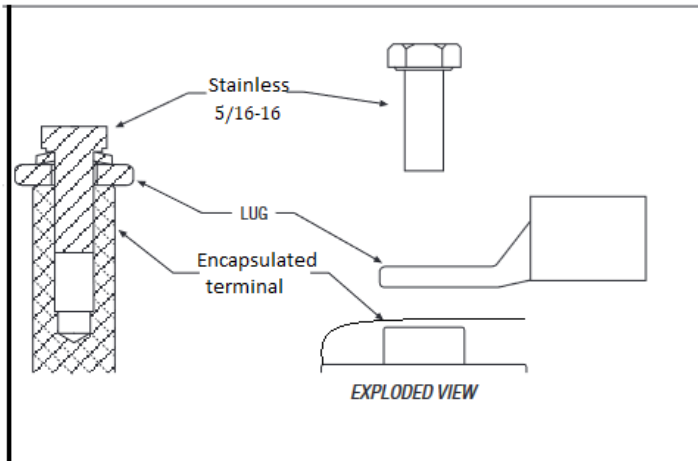

# Low Power Wiring

## Signal Wiring

Signal wires should be kept as short as practical. Care should be taken to protect the wires from sharp edges and rubbing. Consider the use of split loom or braided wire sheathing. Fasten bundles securely to framework. Do not route the signal wires together in the same bundle with power wires.

## Temp Sensor

Induction motors come with a two wire temp sensor which the controller uses to monitor internal temps during operation. On DC conversions the temp sensor will run through the same harness connector as your speed sensor.

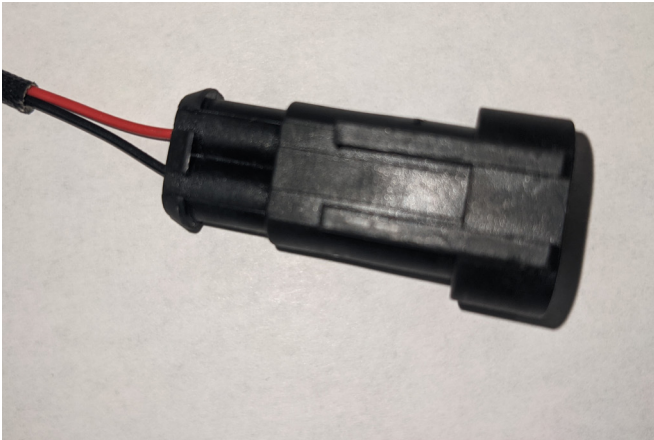

## ***Speed Sensor Information***

The speed sensor is a small group of wires attached to the side of the motor. Induction motors use a Quadrature signal that gives up to 64 readings per minute. Speed sensors are currently required.

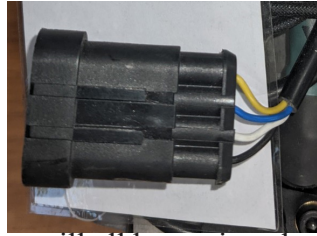

Carts that came stock with an AC motor will all be equipped to use the Quadrature sensor. For AC Conversion applications a harness adapter will be used to get the correct signal to the controller without replacing the existing harness.

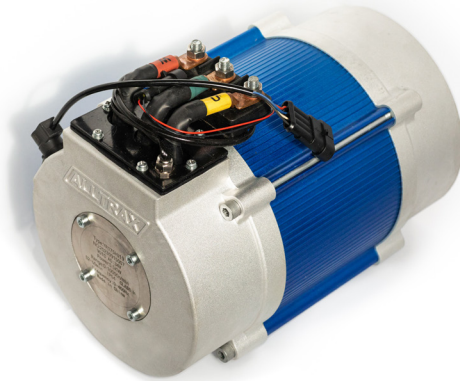

In the future a sensorless option will be available but currently speed sensors are required for all ACT induction applications.

## ***Speed and Temp sensor cable***



All DC conversion systems will come with a new speed and temp sensor cable to match the new AC motor. We recommend not running this harness parallel to your high current wires. An example would be zip tying them to your large gauge motor wires. Even with shielded wires this can potentially cause issues with the signal. Each connector can only be plugged into one location on the cart/controller but there is a full break down of each connector on the following page.

### **Encoder Pulses/Revolution Constraint (Quadrature Encoder)**

The maximum encoder frequency the controller will accept is 10 kHz. To determine how fast this constraint will allow the motor to spin, use the equation:

*Max Speed Encoder Limit = 600000 / Encoder Size*  
(e.g., a motor with 128-pulse encoder can run up to 4587 rpm).

### **Firmware Max Speed Constraint**

The maximum motor speed the controller will allow is 13,000 rpm.

*Max Sped RPM Limit = 13,000*

# MOUNTING PANEL DIMENSIONS

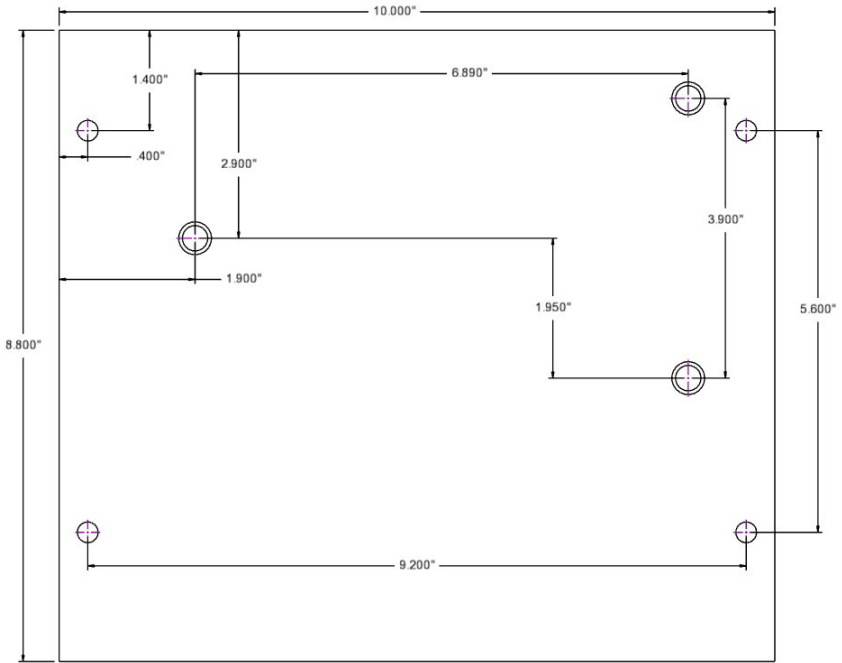

*A fullsize 1:1 scale drawing of this will come with your installation kit. The one shown here is just for referencing dimensions*

# Wire Harness Pinouts

## Speed and Temp sensor harness connectors Used on all DC conversions

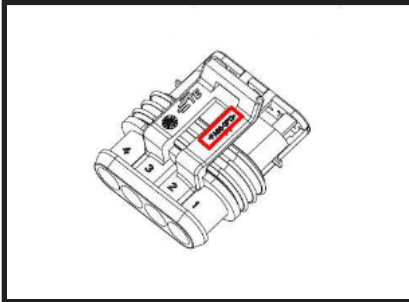

**C3** - TE Superseal 4P connector used for the speed sensor signal of the motor. Water resistant connector.

**C2** - TE Superseal 2P connector used for the motor temp sensor harness. Water resistant connector.

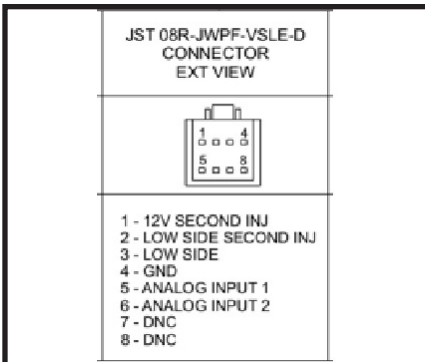
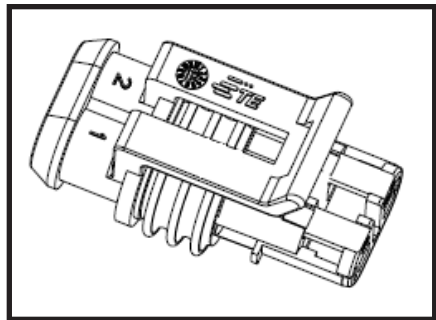

**C1** - JST-JWPF O8 connector used for the controller side connection of the Speed and Temp sensor harness. Water resistant connector.

## ***C1, C2, C3 pinouts for Alltrax harness***

<b>PIN</b>	<b>NAME</b>	<b>DESCRIPTION</b>
<b>**</b>	<b>C1</b>	<b>CONNECTOR</b>
<b>1</b>	Tach Ground	Ground for the speed sensor
<b>2</b>	Tach A	Quadrature A of the speed sensor
<b>3</b>	Tach B	Quadrature B of the Speed sensor
<b>4</b>	+5V Tach	Positive voltage reference
<b>5</b>	Not Used	Not Used
<b>6</b>	Not Used	Not Used
<b>7</b>	Temp Sensor Lo	Motor Temp
<b>8</b>	Temp Sensor Hi	Motor Temp
<b>**</b>	<b>C2</b>	<b>CONNECTOR</b>
<b>1</b>	Temp Sensor Lo	Motor Temp
<b>2</b>	Temp Sensor Hi	Motor Temp
<b>**</b>	<b>C3</b>	<b>CONNECTOR</b>
<b>1</b>	+5V Tach	Positive Voltage Reference
<b>2</b>	Tach A	
<b>3</b>	Tach B	
<b>4</b>	Tach Ground	

# WIRE HARNESS PINOUT

26 pin JAE  
MX23A26S  
For the Yamaha YDRE

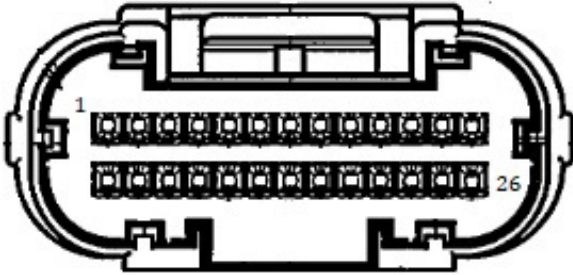

*Female connector, harness side looking face on*

For DC to AC conversions this connector is used on the stock Yamaha YDRE JAE MX23A26 style connector. No changes should need to be made to the factory harness.

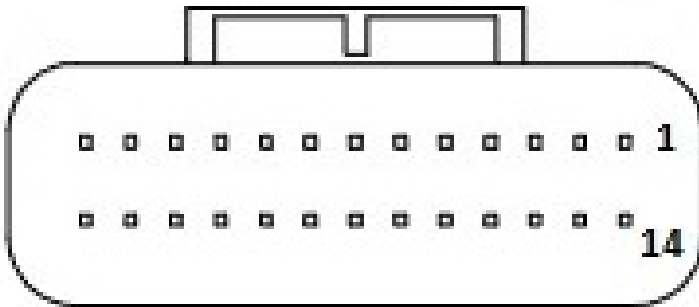

*Male connector, controller side looking down with no harness connected*

## 26 PIN TABLE 1/2

PIN	NAME	DESCRIPTION
1	NA	NOT USED
2	CHARGE INTERLOCK	Voltage signal from the charge port to notify charging status.
3	CONTACTOR NEG	Floating ground for the main contactor.
4	REV BUZZ NEG	Low side of the horn, pulled to ground by controller
5	+5V THROTTLE	5v reference for the throttle circuit.
6	THROTTLE LO	Throttle ground
7	THROTTLE SIG	0-5v output signal from the throttle
8	KEY SWITCH	Voltage from the key to the controller
9	REVERSE	Positive input voltage from the reverse side of the FnR switch
10	FORWARD	Positive input voltage from the forward side of the FnR switch
11	FOOT SWITCH	Positive voltage from the throttle switch
12	TOW/RUN	Battery voltage referene from the TOW/RUN switch
13	TOW/RUN	Battery voltage referene from the TOW/RUN switch

## 26 PIN TABLE 2/2

PIN	NAME	DESCRIPTION
14	NA	
15	NA	
16	USER 2	Not used on the YDRE conversion
17	USER 1	Not used on the YDRE conversion
18	NA	
19	NA	
20	NA	
21	NA	
22	NA	
23	NA	
24	TACH OUT	Not used on the YDRE conversion
25	TACH HI	Not used on the YDRE conversion
26	TACH LO	Not used on the YDRE conversion

# WIRE HARNESS PINOUT

## 23 PIN AMP SEAL connector - G-19, G-22

The majority of low power connections will be made through the 23 pin amp seal connector. The 23 pin connector found on the factory AC Yamahas uses a different pinout than the factory connector on the G19 and G22 connectors.

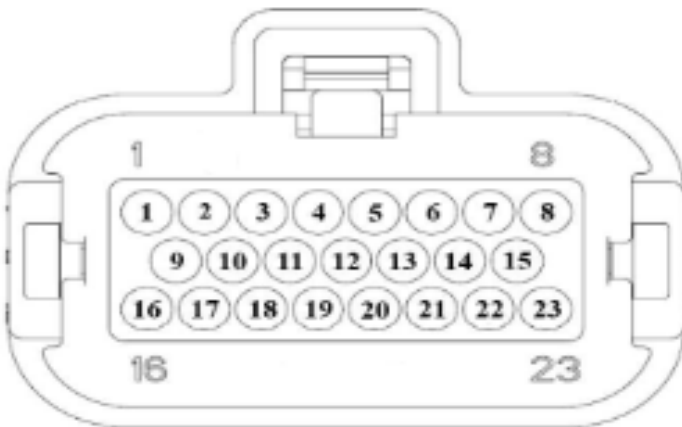

*The image shows the carts wire harness when unplugged and viewed from the rear - where the wires go into the connector itself.*

## 23 PIN TABLE 1/2

PIN	NAME	DESCRIPTION
1	TOW/RUN switch	Main battery reference for the low current system.
2	Not Used	Not Used
3	Foot Switch	Logic signal from throttle switch
4	Forward	Forward signal from direction selector
5	Reverse	Reverse signal from direction selector
6	Keyswitch	Signal input from keyswitch
7	Throttle Wiper	Throttle output signal
8	Throttle Lo	Lo side reference of throttle potentiometer
9	Throttle Hi	Hi side reference of throttle potentiometer
10	Horn	Signal control wire for activating the reverse buzzer.
11	Solenoid Control	Control signal used to engage the Solenoid/Main contactor

## 23 PIN TABLE 2/2

<b>PIN</b>	<b>NAME</b>	<b>DESCRIPTION</b>
12	Not Used	Not Used
13	Solenoid Neg	Some variations of G19 control the solenoid with this wire
14	Tach Output	Output signal from the stock speed sensor. Unused /w AC
15	Tach Reference	Reference signal from speed sensor. Unused /w AC
16	Tach Negative	Ground reference from speed sensor. Unused /w AC
17	User 1	Switching signal used to activate user 1 settings
18	User 2	Switching signal used to activate user 2 settings
19	Not Used	Not Used
20	Not Used	Not Used
21	Not Used	Not Used
22	Not Used	Not Used
23	Not Used	Not Used

# CONTROLLER DIMENSIONS

## TOP DOWN VIEW

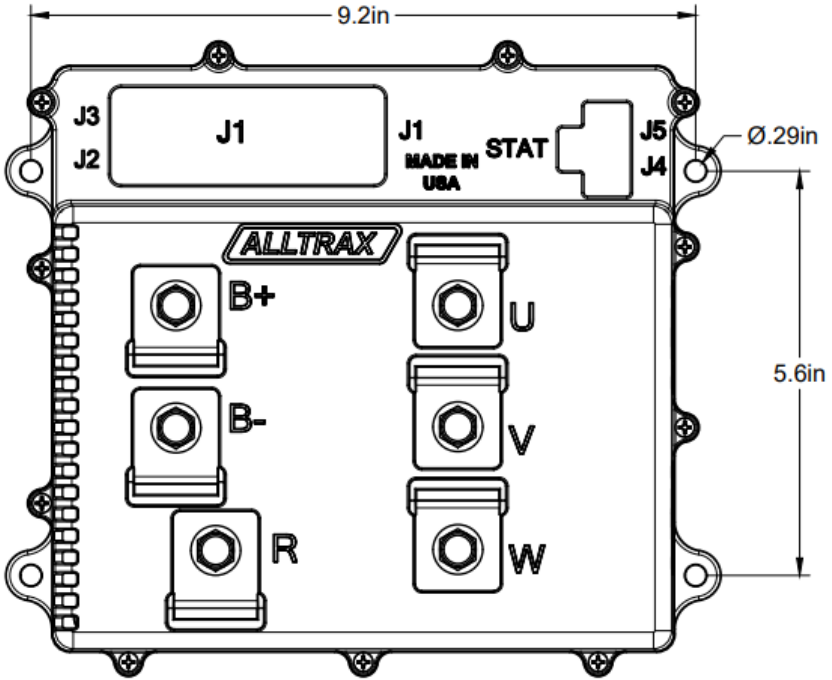

# CONTROLLER DIMENSIONS

## SIDE VIEW

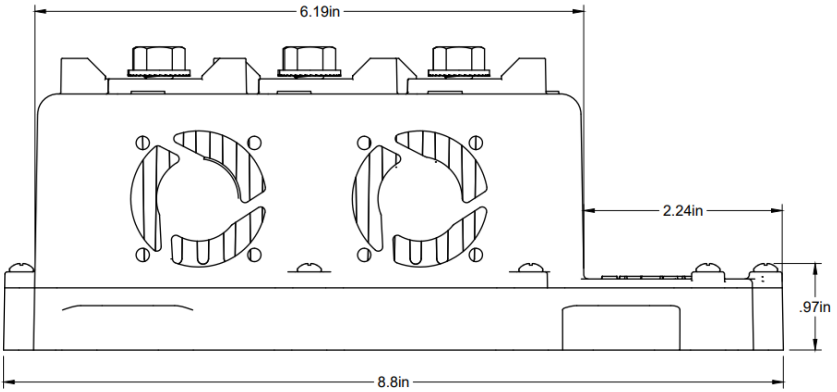

## FRONT VIEW

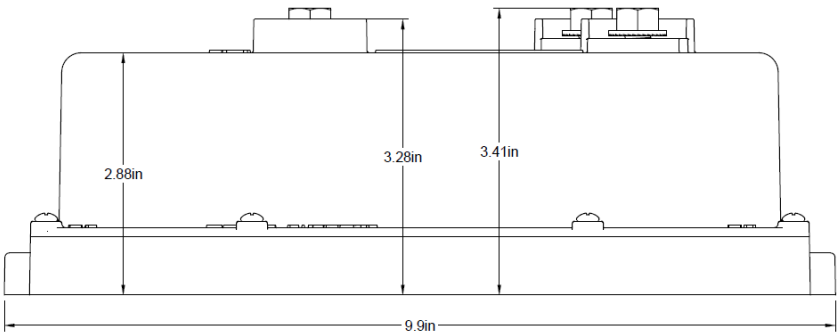

# YAMAHA YDRE CONVERSION

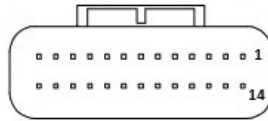
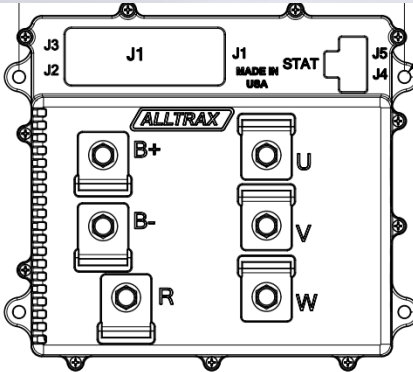

**J1** - For an indepth pinout of the harness see pages 20-22 of this manual

- J1** - Main wire harness connector
- J2** - Personality Switch
- J3** - AC Motor case ground
- J4** - Can Bus
- J5** - Programming port (USB A)

- B+** Positive from Solenoid
- B-** Battery Negative
- R** Not used for conversions
- U** U of the Motor
- V** V of the Motor
- W** W of the Motor



# YAMAHA G19/G22 CONVERSION

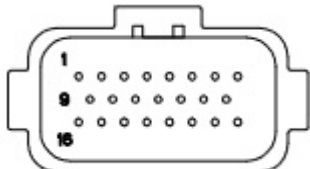
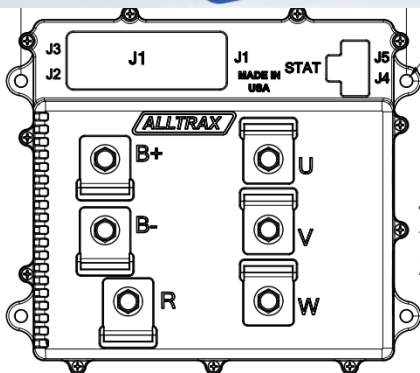

**J1-** For an indepth description of the wire harness see pages 24 - 26 of this manual.

- J1** - Main wire harness connector
- J2** - Personality Switch
- J3** - AC Motor case ground
- J4** - Can Bus
- J5** - Programming port (USB A)

- B+** Positive from Solenoid
- B-** Battery Negative
- R** Not Used
- U** U of the Motor
- V** V of the Motor
- W** W of the Motor



# PROGRAMMING THE CONTROLLER

Controllers ordered for stock configuration come pre-programmed and do not need to be programmed before use. If the user would like to customize their performance or has upgraded their motor and needs a matching motor map the controller can be connected to a computer with a USB A to B, commonly referred to as a “printer cable”.



The USB A to B cable is used to connect your motor controller to your personal computer. Using the free Alltrax Toolkit you can customize your performance to match your needs.

The Alltrax Toolkit software can be  
downloaded from:  
<https://alltraxinc.com/ac-toolkit-software/>  
No purchase necessary

[DOWNLOAD SOFTWARE](#)

## AC Toolkit Software Manual

[AC Toolkit Software Manual](#)

# BLINK CODES

---

On power up, the controller will blink out a throttle code and then a Status or Error Code (see below)

## Throttle Type Codes:

1 Green LED Flash	=	2-wire 0-5k throttle
2 Green LED Flash	=	2-wire 5K-0 throttle
3 Green LED Flash	=	0-5V throttle
4 Green LED Flash	=	EZGO ITS throttle
5 Green LED Flash	=	3-wire 0-5k
6 Green LED Flash	=	6 to 10.5 Taylor Dunn throttle
7 Green LED Flash	=	MCOR
8 Green LED Flash	=	Reserved
9 Green LED Flash	=	Pump
10 Green LED Flash	=	USB Throttle
11 Green LED Flash	=	Absolute Throttle
12 Green LED Flash	=	PWM_Throttle

## Brake Type Codes:

1 Green LED Flash	=	2-wire 0-5k throttle
2 Green LED Flash	=	2-wire 5K-0 throttle
3 Green LED Flash	=	0-5V throttle
4 Green LED Flash	=	Reserved
5 Green LED Flash	=	3-wire 0-5k
6 Green LED Flash	=	6 to 10.5 Taylor Dunn throttle
7 Green LED Flash	=	MCOR
8 Green LED Flash	=	Reserved
9 Green LED Flash	=	Reserved
10 Green LED Flash	=	USB Throttle
11 Green LED Flash	=	Absolute Throttle

# BLINK CODES

## Normal Display Status:

Solid Green Light	=	Controller Ready to Run
Solid Red Light	=	Controller in programming mode
Solid Yellow Light	=	Throttle is wide open and the controller is <u>NOT</u> in Current Limit
Blinking Yellow Light	=	Throttle is wide open, but the controller is in Current Limit

## Error Codes:

AC alarm codes flash a sequence of green then red. All alarms are self clearing and will repeat until the error condition has been corrected.

1 Green and 1 Red LED Flash	=	Short Circuit/Output Fault
1 Green and 2 Red LED Flash	=	Battery Under Voltage
1 Green and 3 Red LED Flash	=	Battery Over Voltage
1 Green and 4 Red LED Flash	=	Over temperature
1 Green and 5 Red LED Flash	=	Throttle Power Fault
1 Green and 6 Red LED Flash	=	Pre-Charge Failure
2 Green and 1 Red LED Flash	=	Throttle/Brake Range
2 Green and 2 Red LED Flash	=	Bad Variables
2 Green and 3 Red LED Flash	=	High Throttle Over range
2 Green and 4 Red LED Flash	=	High Throttle Under range
2 Green and 5 Red LED Flash	=	Low Throttle Over range
2 Green and 6 Red LED Flash	=	Low Throttle Under range
3 Green and 1 Red LED Flash	=	Throttle/Brake Range
3 Green and 2 Red LED Flash	=	Bad Variable Set Loaded
3 Green and 3 Red LED Flash	=	Relay Coil Overcurrent
3 Green and 4 Red LED Flash	=	Brake Coil Overcurrent
3 Green and 5 Red LED Flash	=	Reserved Overcurrent*
3 Green and 6 Red LED Flash	=	Horn Overcurrent
4 Green and 1 Red LED Flash	=	Reserved
4 Green and 2 Red LED Flash	=	Reserved
4 Green and 3 Red LED Flash	=	Hardware Failure
4 Green and 4 Red LED Flash	=	Startup Failure
4 Green and 5 Red LED Flash	=	Reserved
4 Green and 6 Red LED Flash	=	Reserved
5 Green and 1 Red LED Flash	=	General Error

# CODE DEFINITIONS

## Error Code Definitions:

- Short Circuit/Output Fault:  
Controller detected a short circuit or other fault on the output circuit. Check wiring.
- Battery Under Voltage:  
B+ Voltage lower than Low Voltage Battery Setting. Check pack voltage or program settings.
- Battery Over Voltage:  
B+ Voltage Higher than Over Voltage Battery Setting. Check pack voltage or program settings
- Over temperature:  
Busbar temperature exceeds 90°C. Let controller cool and/or add fan.
- Throttle power Fault:  
This is a 5V fault, if the speed sensor gets damaged this alarm will be one of the alarms triggered. Can also be caused by a fault in voltage based throttles
- Pre-charge Failure:  
B+ voltage and KSI voltage differ by more than 5v. Stuck solenoid.
- Under Temp:  
Busbar Temperature reads less than -20°C
- High Throttle Over range & High Throttle Under range:  
High Side of throttle signal is outside of acceptable window for that throttle type. Check and/or replace throttle. Change throttle type to correct throttle installed on car.
- Low Throttle Over range & Low Throttle Under range:  
Low Side of throttle signal is outside of acceptable window for that throttle type. Check and/or replace throttle. Change throttle type to correct throttle installed on car.
- Bad Variable Set Loaded:  
Alltrax loaded variable data is missing or corrupted. Contact Alltrax
- Throttle/Brake Range:  
The RXV has a “throttle” built into the brake pedal to communicate with the motor brake. This alarm indicates an error in that signal.

# CODE DEFINITIONS

## **Error Code Definitions:**

- Relay coil overcurrent:  
Relay coil has shorted, the wires were attached incorrectly or the suppression control diode is backwards.
- Horn Overcurrent:  
There is a short in the horn circuit, could be wiring or horn related

# WARRANTY STATEMENT

---

Alltrax, Inc., (hereafter Alltrax) warrants that the product purchased is free from defects in materials or workmanship for a period of 2 years from the date of manufacture. This warranty does not apply to defects due directly or indirectly to misuse, abuse, negligence, accidents, repairs, improper installation, submersion, alterations or use contrary to any instructions provided by Alltrax in verbal or written form.

In the event you should need warranty repair, contact Alltrax at (541) 476-3565 to receive warranty service authorization instructions for returning the defective product to Alltrax for evaluation. Products or parts shipped by customer to Alltrax must be sent postage paid and packaged appropriately for safe shipment. Alltrax is not responsible for customer products received without warranty service authorization and may be rejected.

Alltrax reserves the right to repair or replace merchandise at its option at no cost to the customer, except for shipping costs of sending the defect item to Alltrax. Replacement shall mean furnishing the customer with a new equivalent product to the defective item. Alltrax also reserves the right to make changes to any of its products or specifications without notice.

Alltrax assumes no liability for applications assistance or customer product design. Customers shall be responsible for evaluating the appropriateness of the use of any Alltrax product in any application. Customers shall provide adequate design and operating safeguards that are in compliance with standard practices of other similar applications or any standards of any governing agency.

**THIS IS ALLTRAX INC.'S, SOLE WARRANTY.**

**NO REPRESENTATIVE EMPLOYEE, DISTRIBUTOR OR DEALER OF ALLTRAX HAS THE AUTHORITY TO MAKE OR IMPLY ANY WARRANTY, REPRESENTATION, PROMISE OR AGREEMENT, WHICH IN ANY WAY VARIES THE TERMS OF THIS LIMITED WARRANTY.**

**ALLTRAX PRODUCTS SOLD TO CUSTOMER ARE INTENDED TO BE USED ONLY IN THE APPLICATION SPECIFIED BY THE CUSTOMER TO ALLTRAX. ANY OTHER USE RENDERS THE LIMITED WARRANTY EXPRESSED HEREIN AND ALL IMPLIED WARRANTIES NULL AND VOID AND SAME ARE HEREBY EXCLUDED.**

## **DISCLAIMER OF IMPLIED WARRANTIES**

**ALLTRAX, INC., SHALL IN NO EVENT BE LIABLE FOR DEATH, INJURIES TO PERSONS OR PROPERTY, OR FOR INCIDENTAL, CONTINGENT, OR CONSEQUENTIAL DAMAGES ARISING FROM THE USE OR MISUSE OF OUR PRODUCTS.**

**EXCEPT SPECIFICALLY PROVIDED HEREIN, THERE ARE NO OTHER WARRANTIES, EXPRESS OR IMPLIED, INCLUDING, BUT NOT LIMITED TO, ANY IMPLIED WARRANTIES OF MERCHANTABILITY OR FITNESS FOR A PARTICULAR PURPOSE. HOWEVER, SOME STATES DO NOT ALLOW LIMITATIONS ON HOW LONG AN IMPLIED WARRANTY LASTS, SO THE PRECEDING EXCLUSION MAY NOT APPLY TO YOU.**

*“Thank you Nikola Tesla, for a better motor”*

**California Proposition**



**65 Warning**



**WARNING:** This product can expose you to chemicals known to the State of California to cause cancer and birth defects or other reproductive harm.

*For more information: [www.P65Warnings.ca.gov](http://www.P65Warnings.ca.gov)*